

VERTIFLO

The Vertical Pump Specialists

PUMPS FOR INDUSTRY

CONTENTS:

Introduction & User List
Product Overview
Vertical Process Pumps Series 600
Vertical Sewage Pumps Series 700
Vertical Sump Pumps Series 800
Vertical Vortex Pumps Series 900
Vertical Cantilever Pumps Series 1100 and 1200
Horizontal End Suction Pumps-Centrifugal Series 1300 and 1400
Horizontal End Suction Pumps-Vortex Series 1500 and 1600
Horizontal Self-priming Pumps- Centrifugal Series 2100
Engineering Sample Specifications

VERTIFLO SERIES 900

Quality Design Features Assure Long, Trouble-Free Service



WIDE RANGE OF APPLICATIONS:

- Chemical Slurries
- Fragile Food Processing Solids
- Paper & Pulp Solids
- Petroleum
- Oils
- Sewage & Waste Treatment
- Textiles

CAPABILITIES:

- Capacities to 1600 GPM
- Heads to 170 Feet
- Temperature to 350° F
- Pit Depths to 26 Feet
- Construction: Cast Iron, 316 Stainless Steel Fitted, All 316 Stainless Steel, Alloy 20, CD4MCu
- Solid Handling up to 4" Diameter Spheres

CONSTRUCTION:

Standard

- All iron construction
- Carbon bottom line shaft bearings
- Carbon intermediate bearings (Pump built for pit depth over 6'-0")
- Fully recessed impeller with wiping vanes
- High thrust, angular contact ball bearing
- 416 stainless steel shaft
- Round, square or oval cover plates
- External impeller adjustment
- Pump setting increments of 1'-0" for pit depths up to 26'-0"
- Flanged suction and discharge on all casings
- Standard C face motors

Options

- Stainless steel fitted, all stainless steel or Alloy 20 construction
- Various line shaft bearing designs
- 316 stainless steel shafting
- Cover plate with manhole, vent or special openings
- Vapor-proof construction
- Various float switch enclosures
- Various liquid level controls
- High water alarm
- Alarm bells and horns
- 316 stainless steel float rod
- 316 stainless steel float
- Below plate discharge "T"

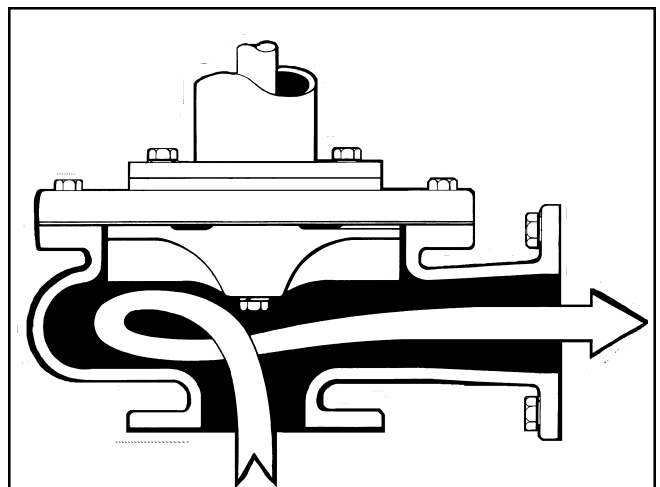

Vortex Design provides an unrestricted flow since the impeller is not normally in contact with the solids being pumped.

1. Motor Support

Assures positive alignment of motor and pump shaft with register fit. Normal thrust, vertical NEMA C face motor standard

2. Flexible Coupling

3. External Impeller Adjustment

High performance maintained without dismantling pump

4. Thrust Bearings

High thrust angular contact bearing. Moisture-proof enclosure, (2) grease seals, purge-type grease lubrication

5. Gas Tight Column Closure

Optional double lip seals available

6. Cover Plate

Designed for specific unit. Optional sizes and gas-tight construction available

7. Column Pipe

Schedule 40 steel with welded flanges

8. Positive Machined Fits

Machined registered fits of column, bearing housing and casing

9. Intermediate Bearing Assembly

Furnished as standard for pit depths in excess of 6'-0". Optional designs for special applications

10. Shafting

Accurately machined 416 stainless steel, 1 1/4", 1 1/2" and 1 5/8" diameter to assure minimum deflection

11. Pump Bearing Assembly

Heavy construction designed for maximum bearing loadings. Optional designs available

12. Bearings

Various materials available to suit most applications

13. Choker Ring

Restricts entrance of abrasives and solids into bottom bearing

14. Impeller

Fully recessed out of flow path. Full length eductor vanes reduce pressure and solid particle buildup behind the impeller

15. Casing

Vortex-type concentric design. Extra heavy wall thickness design for corrosion allowance

16. Discharge Pipe

Schedule 40 flanged pipe and fittings. Below plate "T"-type discharge available

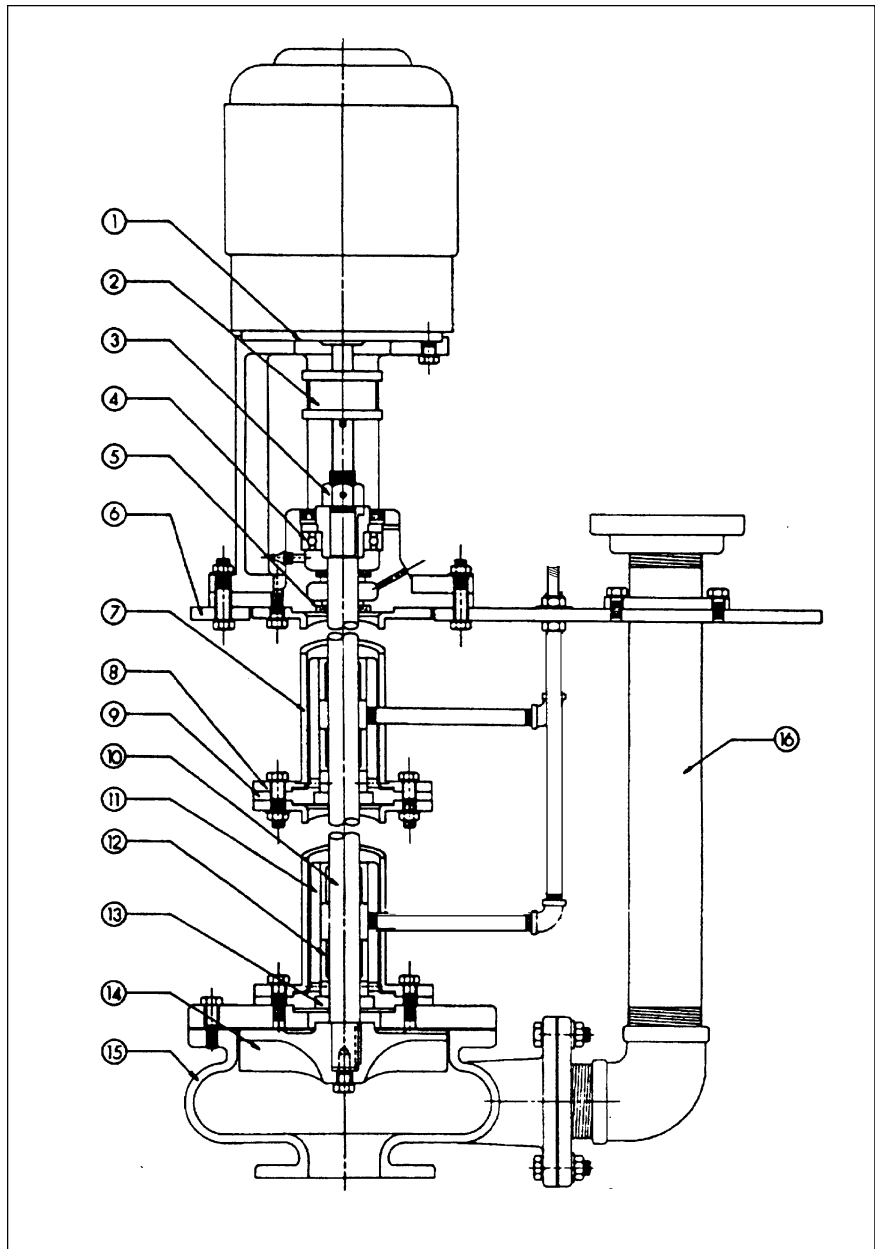

Standard Line Shaft Bearing Assemblies

Lower Bearing Assembly

The standard pump bearing assembly consists of choker ring and (2) guide bearing bushings compatible with the liquid. Standard carbon graphite bearings furnished. Optional: bronze, Teflon* or viton.

Intermediate Bearing Assembly

The standard intermediate assembly consists of (2) guide bearings compatible with the liquid and is standard when pit depth exceeds 6 feet. Standard carbon graphite bearings furnished. Optional: bronze, Teflon* or viton.

*E.I. DuPont registered TM

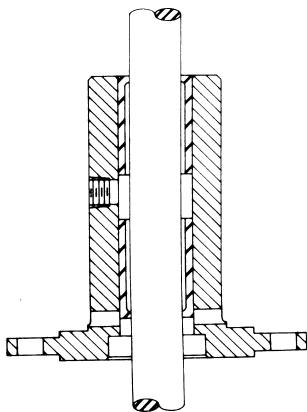

Part Description	Standard Fitted	316 Stainless Fitted	All 316 Stainless	Alloy 20
Motor Support, Thrust Bearing Housing	Cast Iron Class 30	Cast Iron Class 30	Cast Iron Class 30	Cast Iron Class 30
Shaft	Stainless Steel AISI-416	Stainless Steel AISI-316	Stainless Steel AISI-316	Alloy 20
Column	Steel ASTM-A53	Steel ASTM-A53	Stainless Steel AISI-316	Alloy 20
Bearing Housing	Cast Iron Class 30	Cast Iron Class 30	Stainless Steel AISI-316	Alloy 20
Guide Bearings	Graphite	Graphite	Graphite	Graphite
Casing Adaptor	Steel ASTM-53	Steel ASTM-53	Stainless Steel AISI-316	Alloy 20
Impeller	Cast Iron Class 30	Stainless Steel AISI-316	Stainless Steel AISI-316	Alloy 20
Impeller Trim	Stainless Steel AISI-316	Stainless Steel AISI-316	Stainless Steel AISI-316	Alloy 20
Casing	Cast Iron Class 30	Cast Iron Class 30	Stainless Steel AISI-316	Alloy 20
Gasket	Vellumoid	Vellumoid	NA 700	NA 700
Discharge Elbow	Cast Iron AISI-B164	Cast Iron AISI-B164	Stainless Steel AISI-316	Alloy 20
Discharge Pipe	Steel ASTM-A53	Steel ASTM-A53	Stainless Steel AISI-316	Alloy 20
Cover Plate	Steel HRS	Steel HRS	Steel HRS	Steel HRS
Bearing Adaptor	Steel AISI-12L14	Steel AISI-12L14	Steel AISI-12L14	Steel AISI-12L14
Adjusting Nut	Steel ASTM-307	Steel ASTM-307	Steel ASTM-307	Steel ASTM-307
Lip Seal	Nitrile	Nitrile	Nitrile	Nitrile

Alternate Line Shaft Bearing Assemblies

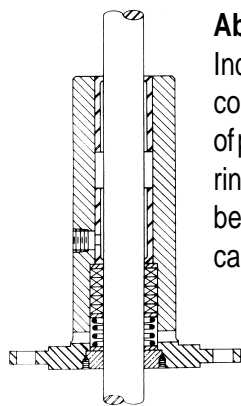

Abrasive Service - 1
Includes (2) guide bearing bushings compatible with the liquid, (5) rings of packing spring loaded and a choker ring to eliminate abrasives from the bearing area. Optional are bronze or carbon graphite.

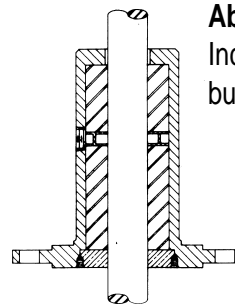

Abrasive Service - 2
Includes (2) cutless rubber bearing bushings for water flush connection.

NOTE: Bearing assemblies shown are typical for most pumping services. Unusual or severe services may necessitate changes in assembly design.

Model Number	Shaft Size	Column Pipe Size	Quantity of Bushings
920	1.250	4.00	2
924	1.500	4.00	2
932	1.9375	6.00	2

VERTIFLO PUMP COMPANY Performance Curves

Curve 11104

Series 900
 Size 1 1/2 X 1 1/2 X 10
 RPM 1750
 Max Sphere 1.5

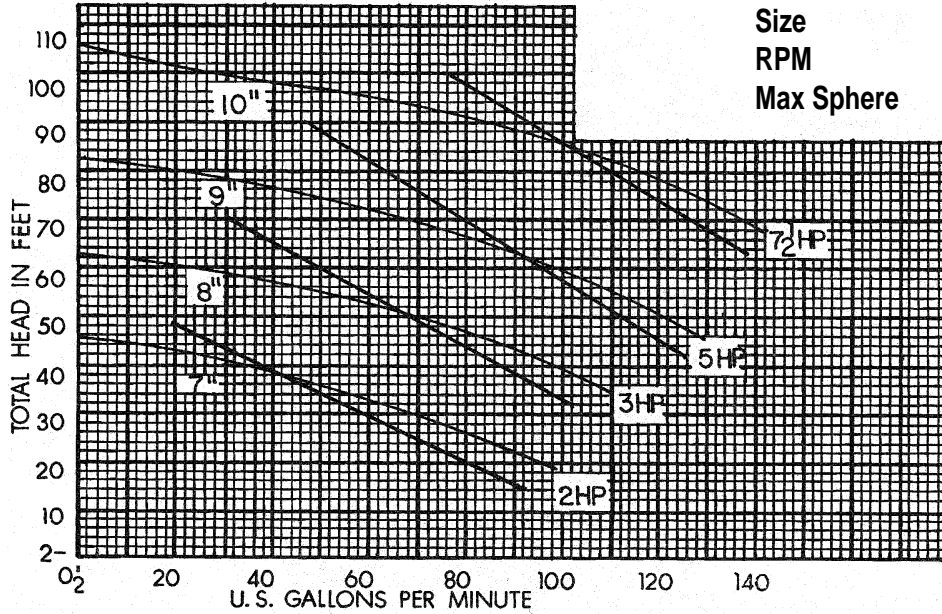

Curve 11106

Series 900
 Size 1 1/2 X 1 1/2 X 10
 RPM 1150
 Max Sphere 1.5

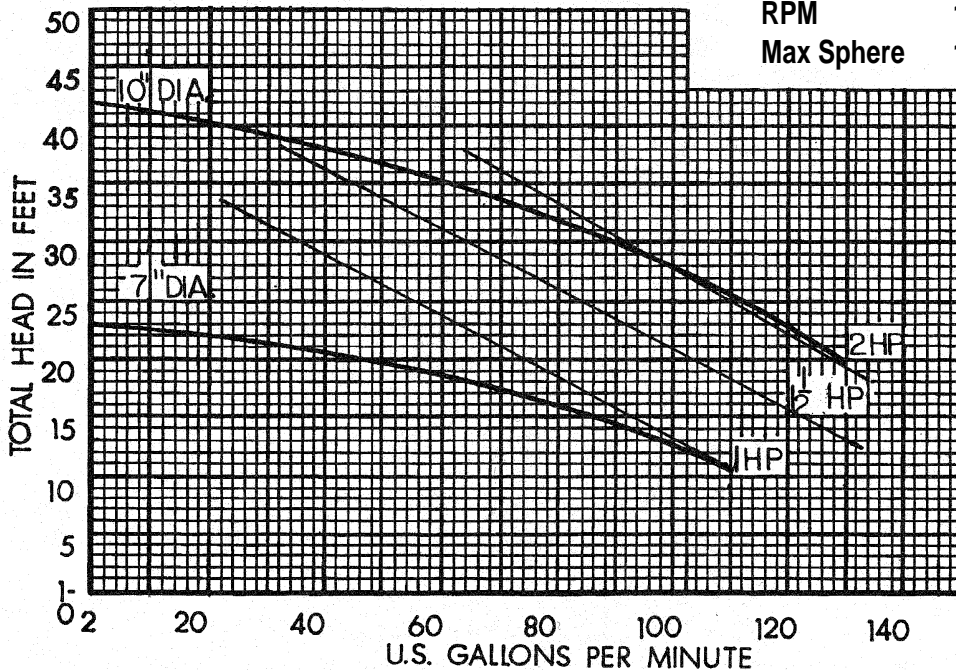

Performance at Casing Discharge Flange

Curves Show Performance with Liquid Having Specific Gravity 1.0 Viscosity • 30 SSU

CUSTOMER _____ CUSTOMER NO. _____

PROJECT _____

ENGINEER _____

CONTRACTOR _____

CONDITIONS: _____ GPM _____ TDH _____ HP _____ EFF% _____ IMP. DIA _____

VERTIFLO PUMP COMPANY Performance Curves

Curve 22104

Series 900
 Size 2 X 2 X 10
 RPM 1780
 Max Sphere 2

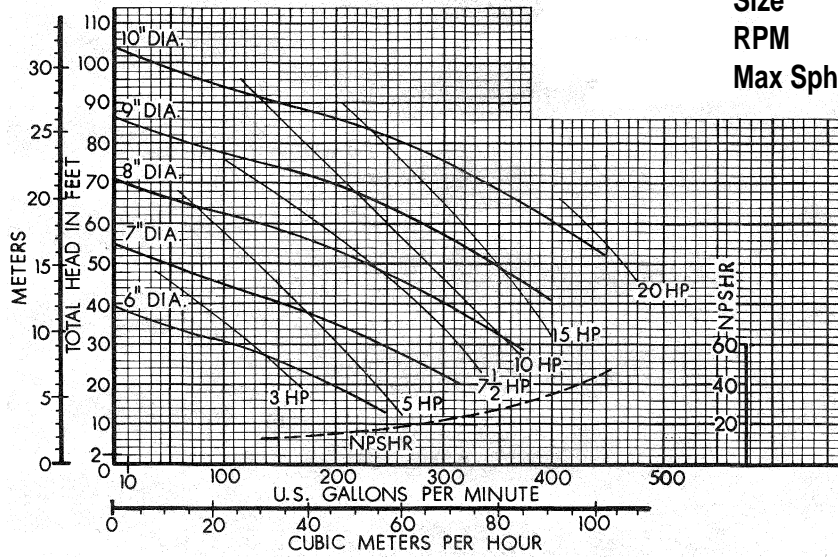

Curve 22106

Series 900
 Size 2 X 2 X 10
 RPM 1180
 Max Sphere 2

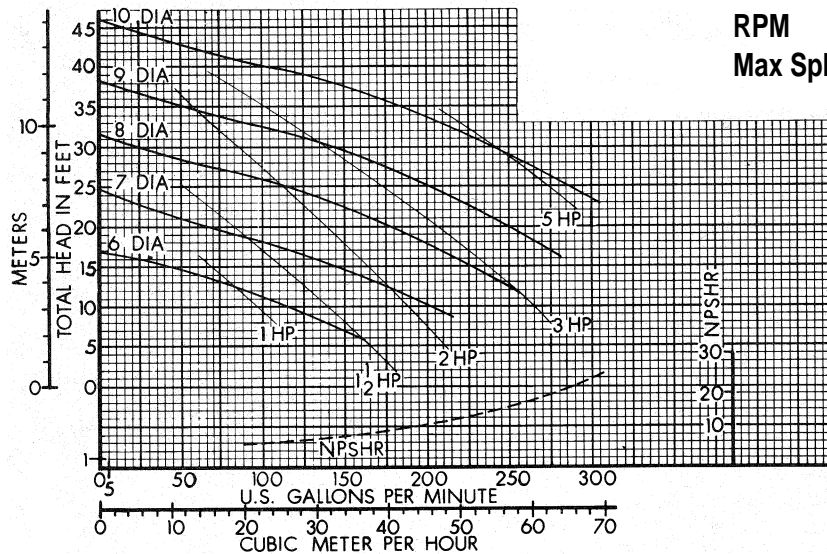

900

Performance at Casing Discharge Flange
 Curves Show Performance with Liquid Having Specific Gravity 1.0 Viscosity • 30 SSU

CUSTOMER _____ CUSTOMER NO. _____
 PROJECT _____
 ENGINEER _____
 CONTRACTOR _____
 CONDITIONS: _____ GPM _____ TDH _____ HP _____ EFF% _____ IMP. DIA _____

VERTIFLO PUMP COMPANY Performance Curves

Curve 33104

Series 900
 Size 3 X 3 X 10
 RPM 1780
 Max Sphere 3

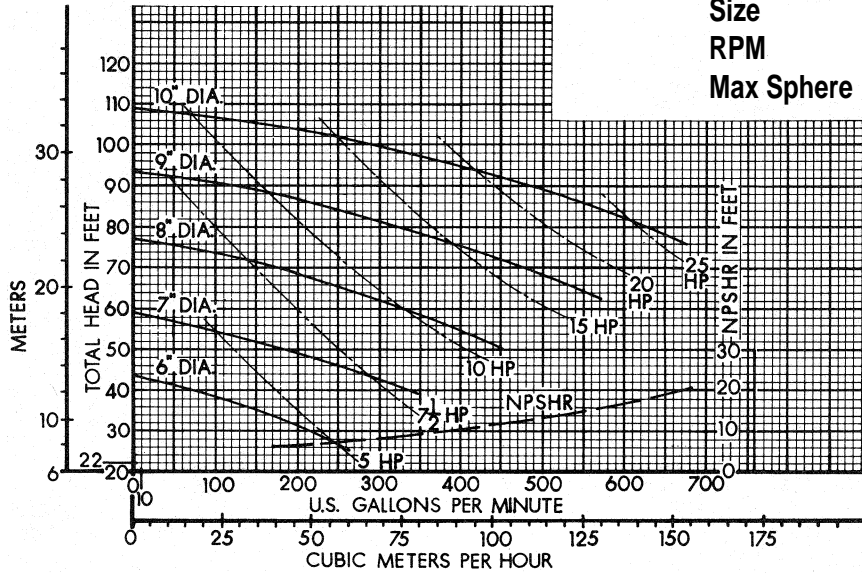

Curve 33106

Series 900
 Size 3 X 3 X 10
 RPM 1180
 Max Sphere 3

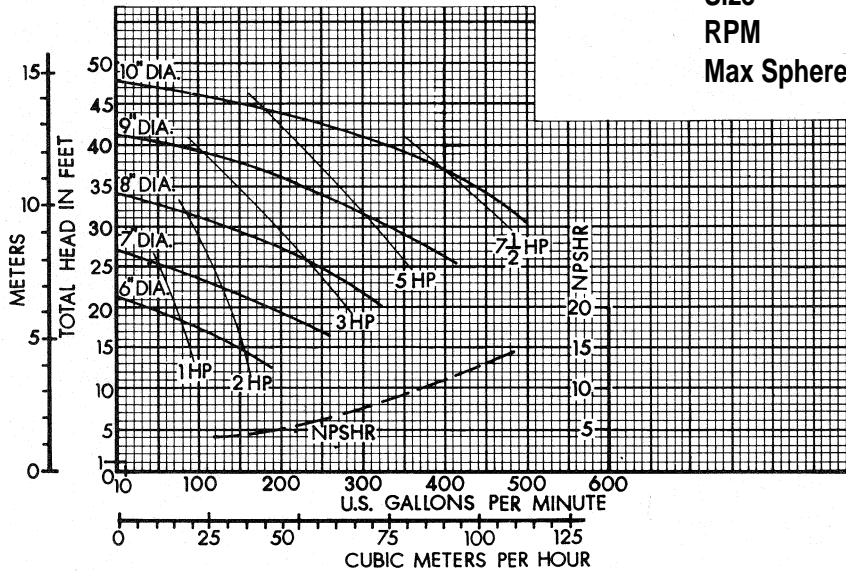

Performance at Casing Discharge Flange

Curves Show Performance with Liquid Having Specific Gravity 1.0 Viscosity • 30 SSU

CUSTOMER _____ CUSTOMER NO. _____

PROJECT _____

ENGINEER _____

CONTRACTOR _____

CONDITIONS: _____ GPM _____ TDH _____ HP _____ EFF% _____ IMP. DIA _____

VERTIFLO PUMP COMPANY Performance Curves

Curve 44104

Series 900
 Size 4 X 4 X 10
 RPM 1780
 Max Sphere 4

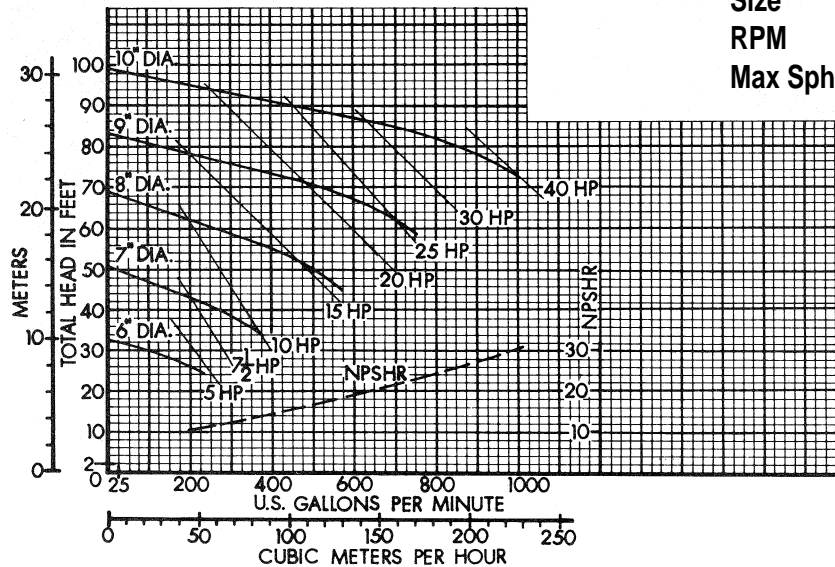

Curve 44106

Series 900
 Size 4 X 4 X 10
 RPM 1180
 Max Sphere 4

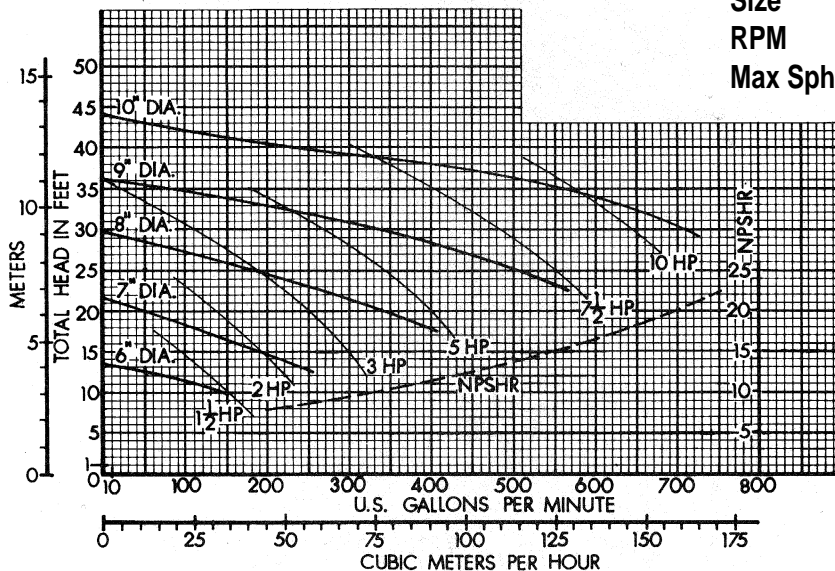

Performance at Casing Discharge Flange

Curves Show Performance with Liquid Having Specific Gravity 1.0 Viscosity • 30 SSU

CUSTOMER _____ CUSTOMER NO. _____

PROJECT _____

ENGINEER _____

CONTRACTOR _____

CONDITIONS: _____ GPM _____ TDH _____ HP _____ EFF% _____ IMP. DIA _____

VERTIFLO PUMP COMPANY Performance Curves

Curve 86104

Series 900
 Size 8 X 6 X 10
 RPM 1780
 Max Sphere 6

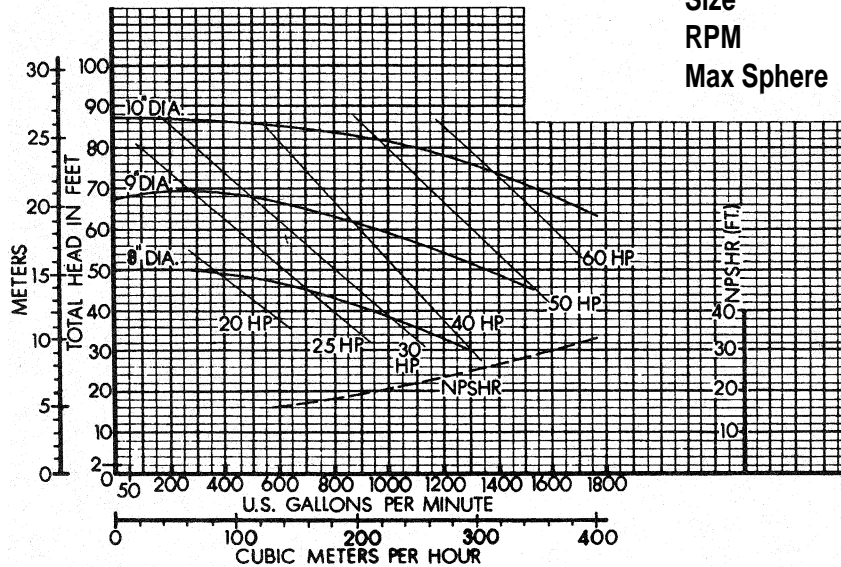

Curve 86106

Series 900
 Size 8 X 6 X 10
 RPM 1180
 Max Sphere 6

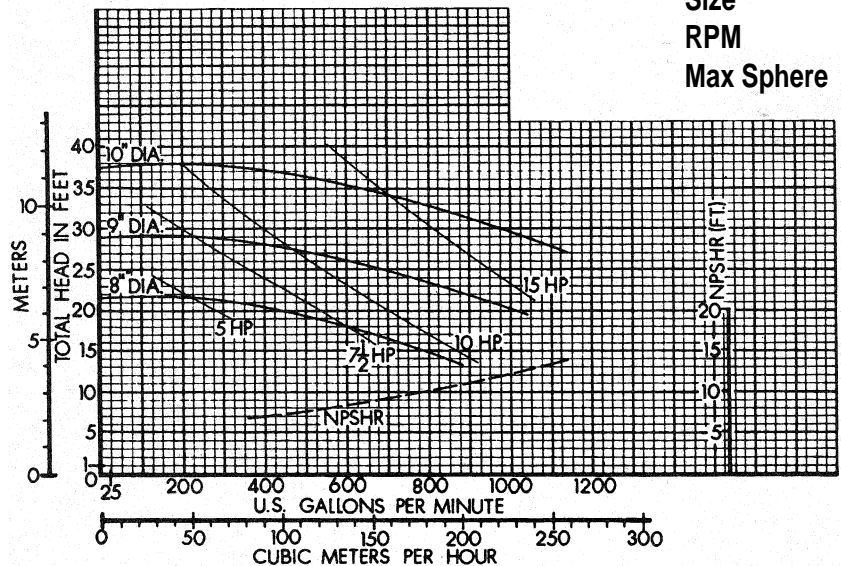

Performance at Casing Discharge Flange

Curves Show Performance with Liquid Having Specific Gravity 1.0 Viscosity • 30 SSU

CUSTOMER _____ CUSTOMER NO. _____

PROJECT _____

ENGINEER _____

CONTRACTOR _____

CONDITIONS: _____ GPM _____ TDH _____ HP _____ EFF% _____ IMP. DIA _____

VERTIFLO PUMP COMPANY Performance Curves

Curve 44134

Series 900
 Size 4 X 4 X 13
 RPM 1780
 Max Sphere 4

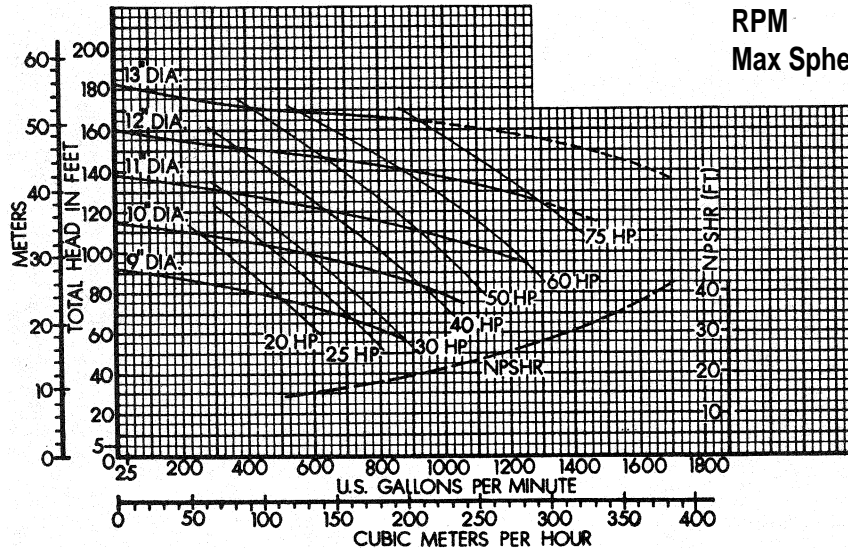

Curve 44136

Series 900
 Size 4 X 4 X 13
 RPM 1180
 Max Sphere 4

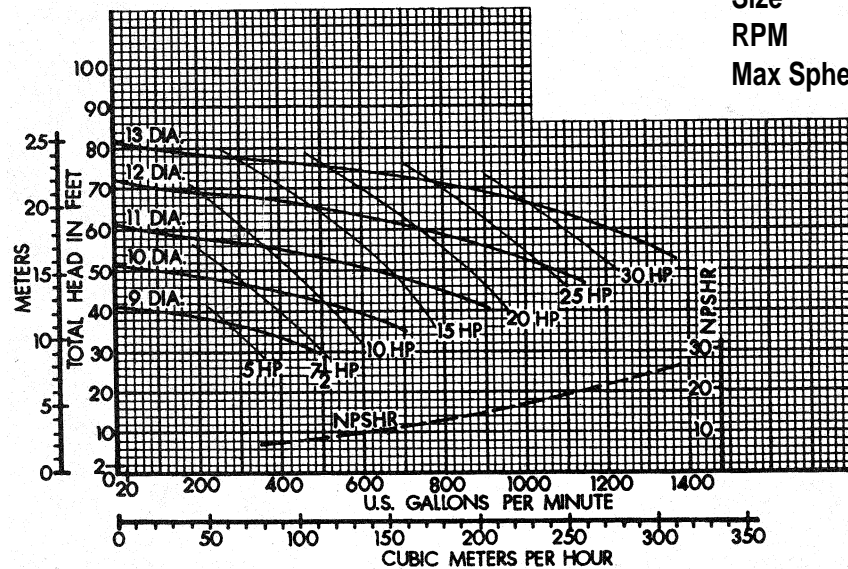

900

Performance at Casing Discharge Flange

Curves Show Performance with Liquid Having Specific Gravity 1.0 Viscosity • 30 SSU

CUSTOMER _____ CUSTOMER NO. _____

PROJECT _____

ENGINEER _____

CONTRACTOR _____

CONDITIONS: _____ GPM _____ TDH _____ HP _____ EFF% _____ IMP. DIA _____

VERIFLO PUMP COMPANY Dimensions

900 Series Basic Oval

PUMP DATA

SIZE	MODEL	A	B	C	D	E	F	H	J	K	L	M	N
1½x1½x10	920	1½	2 TO 20" IN 1" INCREMENTS	18	26	8	4	7½	13½	5¾	13¼	6½	¾
		2							14		13¾		
2x2x10	920	2		21	30	9½	4½	7½	16½	3¼	14½	6½	¾
		3											
3x3x10	924	3		21	34	9	4½	7½	19	13¾	16¾	7	½
		4											
4x4x10	924	4		21	34	9½	4½	7¾	21½	11¾	18¾	7	½
		6											
8x6x10	924	6		24	39	11	7	8¾	23¾	8¾	20	8	½
		8											
4x4x13	924	4		24	39	11	7½	9¾	21½	10¾	18¾	8	½
		6											

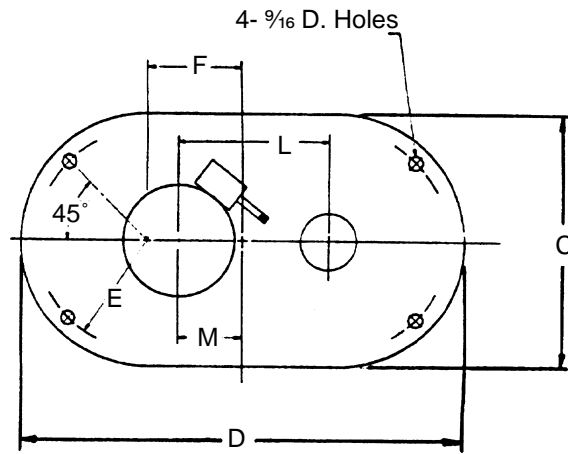

MOTOR DATA

FRAME	P	Q
56 C	10 ⁷ / ₁₆	12
143 TC	10	12
145 TC	10 ⁷ / ₁₆	12
182 - 184 TC	13 ¹ / ₂	12
213 TC	15 ¹ / ₂	12
215 TC	17	12
254 TC	20 ³ / ₈	12
256 TC	21 ³ / ₈	12
284 TC	22 ³ / ₈	13
286 TC	23 ³ / ₈	13
324 TC	24 ³ / ₄	13 ¹ / ₂
326 TC	26 ¹ / ₈	13 ¹ / ₂
364 TC	26 ¹ / ₂	16 ⁵ / ₈
365 TC	27 ¹ / ₂	16 ⁵ / ₈

"K" dimension shown is for a pump built for a 2' through 6' pit depth. For each additional column section, subtract 3/8" from "K."

(1) 920 + 924 = 4"
932 = 6"

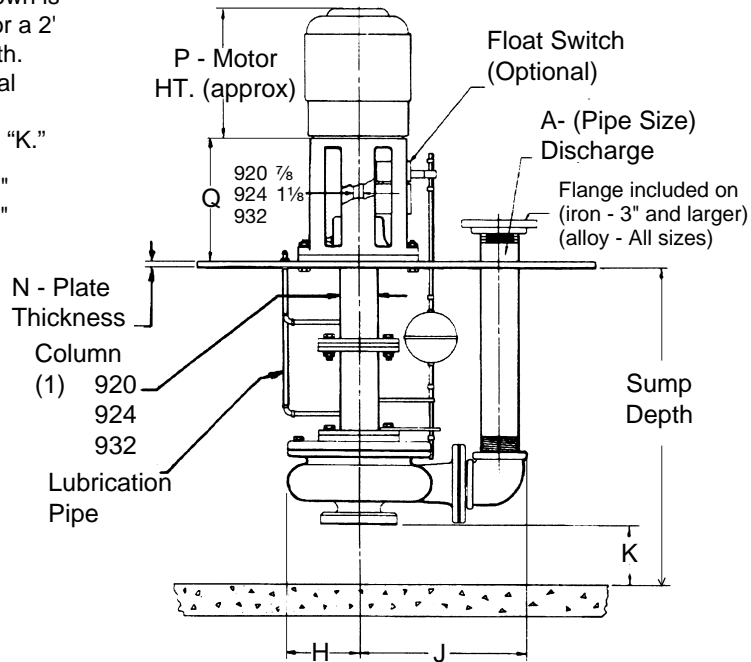

Not for construction unless certified, some dimensions may vary ± 1/2". Pump Construction: _____

CUSTOMER _____ CUSTOMER NO. _____
 PROJECT _____ SERIAL NO. _____
 ENGINEER _____ LOCATION _____
 CONTRACTOR _____
 PUMP Model Size Curve No. GPM Head SP. GR. @Temp. Pump Length Plate
 DATA _____
 MOTOR Mfgr. HP RPM Volt-Phase-Cycle Frame ENC. Furnished by Mounted by
 DATA _____
 Shop Order _____ Certified by _____ Date _____

VERTIFLO PUMP COMPANY Dimensions

900 Series Simplex

PUMP DATA

SIZE	MODEL	A	B	C	D	E	F	H	J	K	L	M	N
1½x1½x10	920	1½	24	28	13	26	7½	13⅝	5⅝	13¼	6½	¾	
		2											
2x2x10	920	2	30	34	16	32	7½	16⅝	3¼	14½	6⅝	¾	
		3											
3x3x10	924	3	30	34	16	32	7½	19	13⅝	16¾	6⅝	¾	
		4											
4x4x10	924	4	36	40	19	38	7¾	21⅝	11¾	18⅝	7¼	½	
		6											
8x6x10	932	6	36	40	19	38	8¾	23⅝	8⅝	20	7¼	5⅝	
		8											
3x3x13	924	3	36	40	19	38	9¾	20¼	12⅝	18	7¼	5⅝	
		4											
4x4x13	932	4	36	40	19	38	9¾	21⅝	10¾	18⅝	7¼	5⅝	
		6											

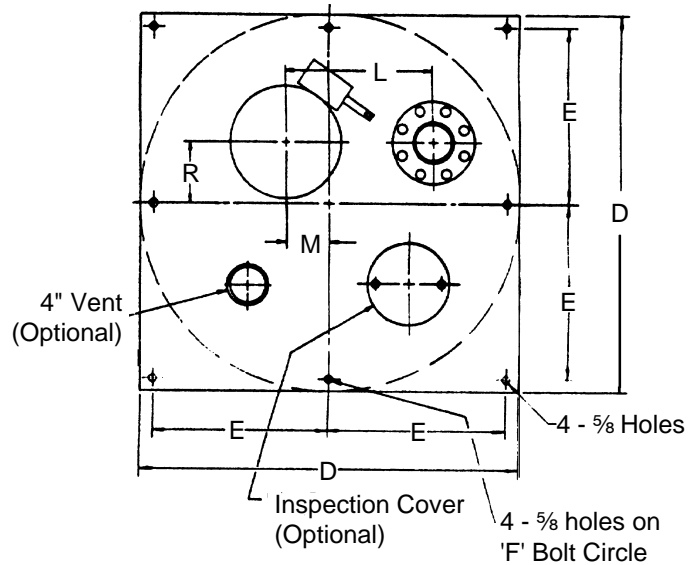

MOTOR DATA

FRAME	P	Q
56 C	10⅞	20½
143 TC	10	20½
145 TC	10⅞	20½
182 - 184 TC	13½	20½
213 TC	15½	20½
215 TC	17	20½
254 TC	20⅝	20½
256 TC	21⅞	20½
284 TC	22⅝	21¼
286 TC	23⅞	21¼
324 TC	24¾	21¼
326 TC	26⅝	21¼
364 TC	26½	22⅝
365 TC	27½	22⅝

"K" dimension shown is for a pump built for a 2' through 6' pit depth. For each additional column section, subtract 3/8" from "K."

(1) 920 + 924 = 4"
932 = 6"

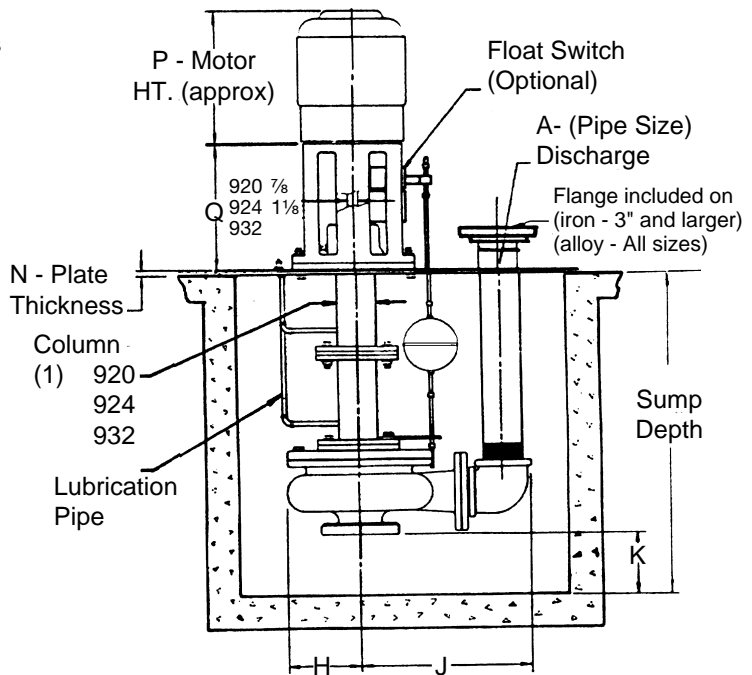

Not for construction unless certified, some dimensions may vary ± 1/2". Pump Construction: _____

CUSTOMER _____ CUSTOMER NO. _____
 PROJECT _____ SERIAL NO. _____
 ENGINEER _____ LOCATION _____
 CONTRACTOR _____
 PUMP Model _____ Size _____ Curve No. _____ GPM _____ Head _____ SP. GR. @Temp. _____ Pump Length _____ Plate DATA _____
 MOTOR Mfg. _____ HP _____ RPM _____ Volt-Phase-Cycle _____ Frame ENC. _____ Furnished by _____ Mounted by DATA _____
 Shop Order _____ Certified by _____ Date _____

VERTIFLO PUMP COMPANY Dimensions

900 Series Duplex

PUMP DATA

SIZE	MODEL	A	B	C	D	E	F	H	J	K	L	M	N	G	
1½x1½x10	920	1½	2	2' TO 20' IN 1' INCREMENTS	48	54	25½	51	7½	13¾	5¾	13¼	6½	½	11
		2			54	60	28½	57	7½	16½	3¼	14½	6½	½	11
3	60	66	31½		63	7½	19	13¾	16¾	7	½	11			
4	60	66	31½		63	7¾	21½	11¾	18¾	8	½	12½			
6	60	66	31½		63	8¾	23¾	8¾	20	8	5/8	12½			
8	60	66	31½		63	9¾	21½	10¾	18¾	8	5/8	12½			
2x2x10	920	2	3	2' TO 20' IN 1' INCREMENTS	54	60	28½	57	7½	16½	3¼	14½	6½	½	11
		3			60	66	31½	63	7½	19	13¾	16¾	7	½	11
4	60	66	31½		63	7¾	21½	11¾	18¾	8	½	12½			
6	60	66	31½		63	8¾	23¾	8¾	20	8	5/8	12½			
8	60	66	31½		63	9¾	21½	10¾	18¾	8	5/8	12½			
10	60	66	31½		63	10¾	21½	10¾	18¾	8	5/8	12½			
3x3x10	924	3	4	2' TO 20' IN 1' INCREMENTS	60	66	31½	63	7½	19	13¾	16¾	7	½	11
		4			60	66	31½	63	7¾	21½	11¾	18¾	8	½	12½
6	60	66	31½		63	8¾	23¾	8¾	20	8	5/8	12½			
8	60	66	31½		63	9¾	21½	10¾	18¾	8	5/8	12½			
10	60	66	31½		63	10¾	21½	10¾	18¾	8	5/8	12½			
12	60	66	31½		63	11¾	21½	10¾	18¾	8	5/8	12½			
4x4x10	924	4	6	2' TO 20' IN 1' INCREMENTS	60	66	31½	63	7¾	21½	11¾	18¾	8	½	12½
		6			60	66	31½	63	8¾	23¾	8¾	20	8	5/8	12½
8	60	66	31½		63	9¾	21½	10¾	18¾	8	5/8	12½			
10	60	66	31½		63	10¾	21½	10¾	18¾	8	5/8	12½			
12	60	66	31½		63	11¾	21½	10¾	18¾	8	5/8	12½			
14	60	66	31½		63	12¾	21½	10¾	18¾	8	5/8	12½			
8x6x10	932	6	8	2' TO 20' IN 1' INCREMENTS	60	66	31½	63	8¾	23¾	8¾	20	8	5/8	12½
		8			60	66	31½	63	9¾	21½	10¾	18¾	8	5/8	12½
10	60	66	31½		63	10¾	21½	10¾	18¾	8	5/8	12½			
12	60	66	31½		63	11¾	21½	10¾	18¾	8	5/8	12½			
14	60	66	31½		63	12¾	21½	10¾	18¾	8	5/8	12½			
16	60	66	31½		63	13¾	21½	10¾	18¾	8	5/8	12½			
4x4x13	932	4	6	2' TO 20' IN 1' INCREMENTS	60	66	31½	63	9¾	21½	10¾	18¾	8	5/8	12½
		6			60	66	31½	63	10¾	21½	10¾	18¾	8	5/8	12½

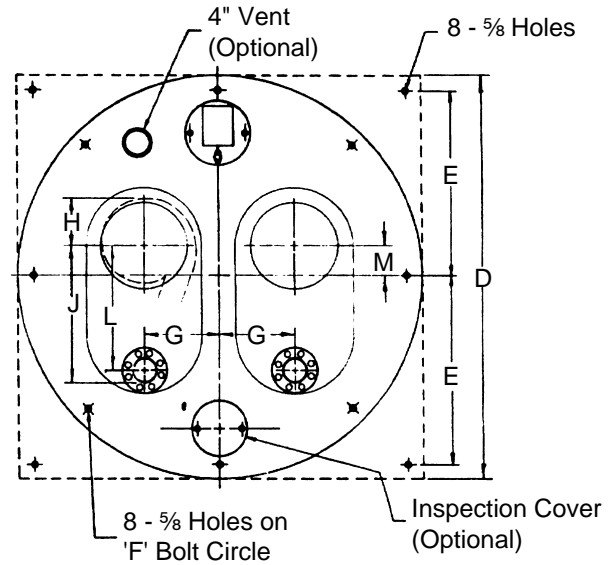

MOTOR DATA

FRAME	P	Q
56 C	10 ⁷ / ₁₆	12
143 TC	10	12
145 TC	10 ⁷ / ₁₆	12
182 - 184 TC	13½	12
213 TC	15½	12
215 TC	17	12
254 TC	20 ⁷ / ₈	12
256 TC	21 ⁷ / ₈	12
284 TC	22 ³ / ₈	13
286 TC	23 ³ / ₈	13
324 TC	24 ³ / ₄	13½
326 TC	26 ¹ / ₈	13½
364 TC	26½	16 ⁵ / ₈
365 TC	27½	16 ⁵ / ₈

"K" dimension shown is for a pump built for a 2' through 6' pit depth. For each additional column section, subtract 3/8" from "K."

(1) 920 + 924 = 4"
932 = 6"

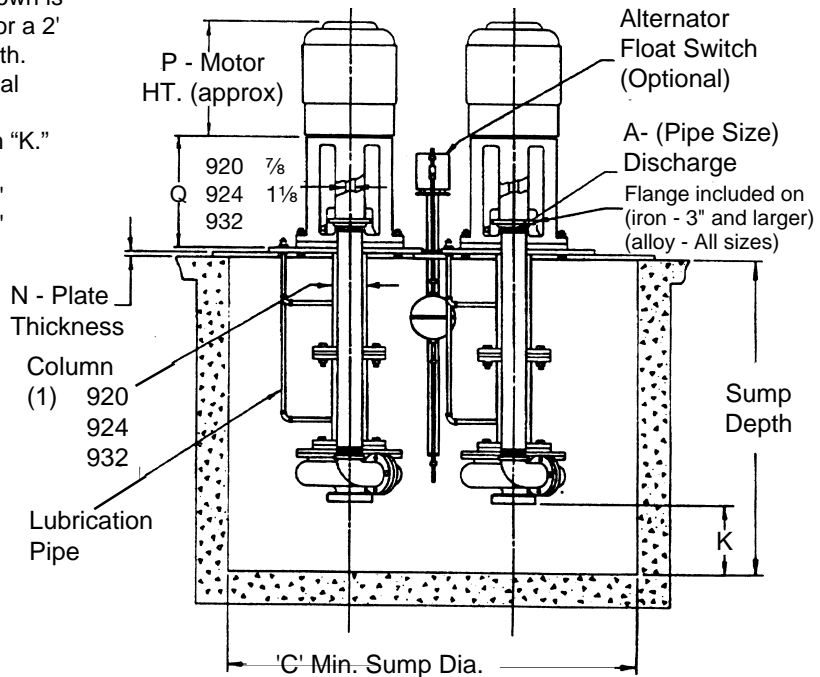

Not for construction unless certified, some dimensions may vary ± 1/2". Pump Construction: _____

CUSTOMER _____ CUSTOMER NO. _____
 PROJECT _____ SERIAL NO. _____
 ENGINEER _____ LOCATION _____
 CONTRACTOR _____
 PUMP Model Size Curve No. GPM Head SP. GR. @Temp. Pump Length Plate
 DATA _____
 MOTOR Mfgr. HP RPM Volt-Phase-Cycle Frame ENC. Furnished by Mounted by
 DATA _____
 Shop Order _____ Certified by _____ Date _____